

GIOTTO PROFESSIONAL is the most innovative UPGRADABLE electric **in-ceiling** projection screen on the market. Its mechanical construction makes it an ideal and unique solution for in-ceiling installations both in residential and AV professional environments.

The Giotto is easy to mount and has the **possibility to install the roller tube with projection cloth after the installation is finished.**

This peculiar feature allows also to easily substitute the projection surface if required by the customer for maintenance reasons, or necessity to upgrade the projection cloth.

Available in 4:3, 1:1 and 16:10 formats or bespoke sizes.

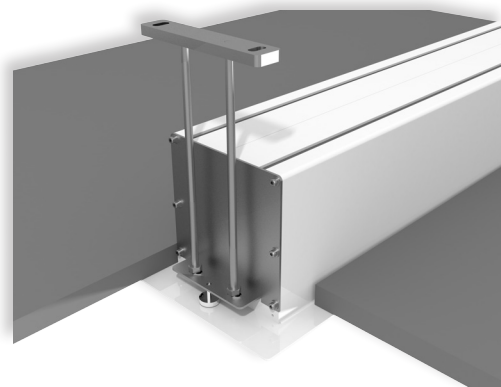

LEFT SIDE VIEW

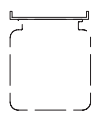

n.2
Ceiling
mounting
brackets



n.1
On/off
switcher

INCLUDED

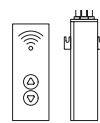

Kit RF Remote
control with
external
receiver



Interface
switch 12 volt



Low voltage
contact
interface



Nm 9
Rpm 26

Faster and
quiet motor

OPTIONAL pag 62-63



CEILING BRACKET

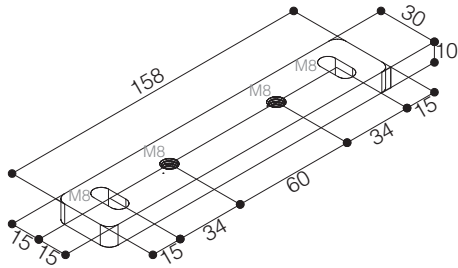

DIMENSIONS OF THE HOLE TO BE MADE IN THE FALSE CEILING

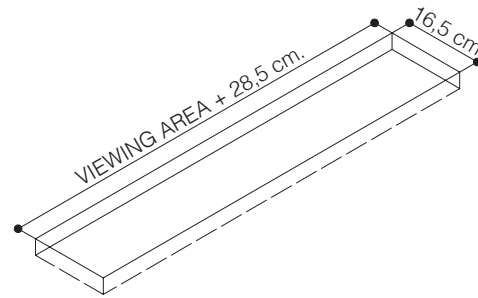

HOUSING SIDE VIEW

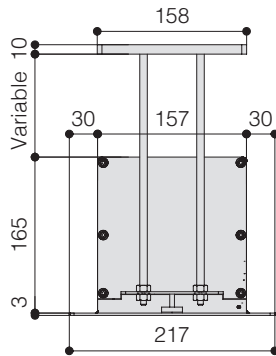

HOUSING FRONT VIEW

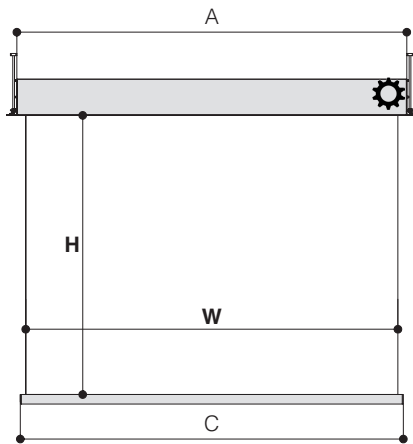
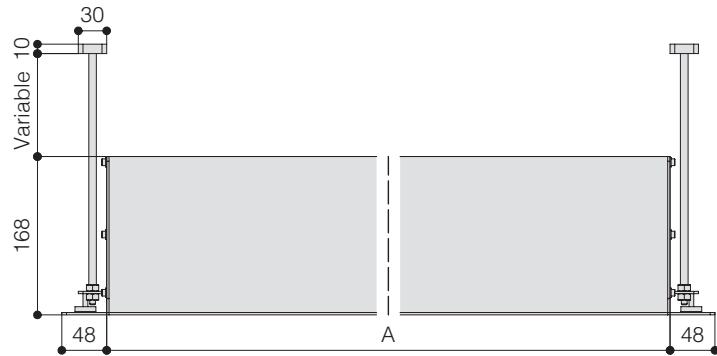

TECHNICAL SPECIFICATIONS

- Silent motor system provides a smooth and quiet operation
 - Up to 300 cm.*
 - From 300 cm.*
- Power: **6 Nm** / **10 Nm**
- Speed: **17 rpm** / **17 rpm**
- Power supply: **230V / 50 Hz** / **230V / 50 Hz**
- Consumption: **137 W** / **156 W**
- Certification: **IMQ** / **IMQ**
- Housing manufactured from aluminium
- Lower part of the housing, trap door and bezel sprayed with white epoxy powders (RAL 9010)
- White dowel bar: height 35 mm. - depth 20 mm.
- Two ceiling mounting brackets with four threaded rods 100 cm. long
- On/Off switcher included
- Flame retardant projection surfaces - classification M1, M2 and B1
- Minimum height required in the false ceiling: 17 cm
- Screen housing available in different colours (*optional*)

The measures in the drawings are expressed in millimetres.

DIMENSIONS measures in cm

1:1 Ratio Viewing area (WxH)	4:3 Ratio Viewing area (WxH)	16:10 Ratio Viewing area (WxH)	16:9 Ratio Viewing area (WxH)	Overall dimensions A - C	Approx. net weight (Kg)
160 x 160	160 x 120	160 x 100	160 x 90	180,5 - 164	22
180 x 180	180 x 135	180 x 112	180 x 101	200,5 - 184	25
200 x 200	200 x 150	200 x 125	200 x 112	220,5 - 204	28
220 x 220	220 x 165	220 x 137	220 x 124	240,5 - 224	31
250 x 250	250 x 190	250 x 156	250 x 140	270,5 - 254	35
300 x 300	300 x 225	300 x 187	300 x 169	320,5 - 304	43
350 x 350	350 x 265	350 x 219	350 x 197	370,5 - 354	50
400 x 400	400 x 300	400 x 250	400 x 225	420,5 - 404	58
-	450 x 340	450 x 281	450 x 253	470,5 - 454	65

PROJECTION CLOTHS

Front projection surfaces	Gain	Rear projection surfaces <i>**no black borders**</i>	Gain
White	1.2	Rear Plus	1.1
Matte White	1.2	Front Rear	0.9
Microperforated	1.1		
Lumi-Grey Microperforated	0.8		
Fibre Matte*	1.25		
Ultra HD*	1.2		
Bright Contrast 3D 0.8*	0.8		

*Limited in height

Warranty: 5 years on the motor - 24 months on the other components

