



MAJOR screen has the same features of the Compact model but guarantees high quality images on bigger dimensions.

This screen is a very good solution for projections to a large audience.

It can be equipped with different types of fabric according to customer's needs.

Available in 4:3, 1:1 and 16:10 ratios or bespoke sizes.



False ceiling trim kit
(optional - for details see p. 48)

Major with black borders (optional)

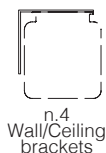

n.4
Wall/Ceiling
brackets



n.1
On/off
switcher

INCLUDED

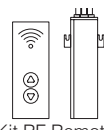

Kit RF Remote
control with
external
receiver

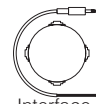

Interface
switch 12 volt

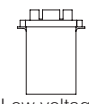

Low voltage
contact
interface



Faster and
quiet motor

OPTIONAL pag 62-63



DROP OF PROJECTION CLOTH
STANDARD

FRONT DROP OF PROJECTION CLOTH
(optional)

WALL-CEILING BRACKET

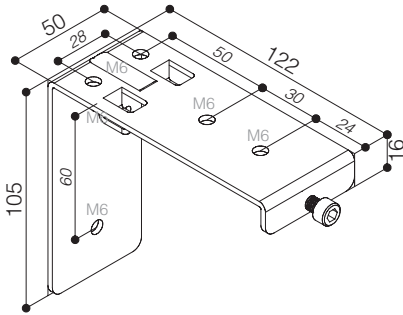

HOUSING DIMENSIONS

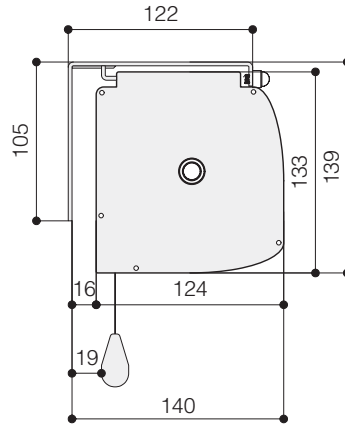

WALL MOUNTING

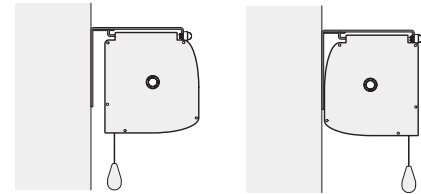

CEILING MOUNTING

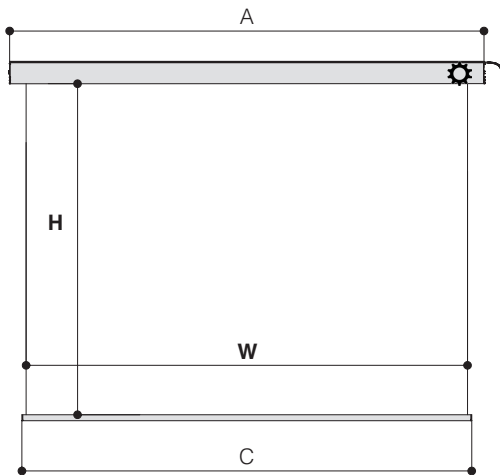
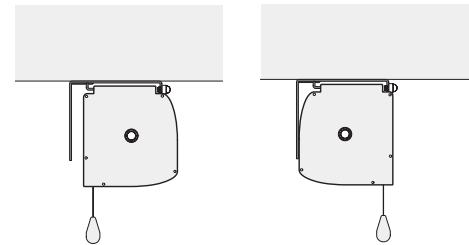

TECHNICAL SPECIFICATIONS

- Silent motor system provides a smooth and quiet operation
 - Power: **10 Nm**
 - Speed: **17 rpm**
 - Power supply: **230V / 50 Hz**
 - Consumption: **156 W**
 - Certification: **IMQ**
- Totally manufactured from aluminium
- Smart design and easy to install
- Housing dimensions: 124x133 mm. (DxH)
- Housing painted with white epoxy powders (RAL 9010)
- White dowel bar: height 35 mm. - depth 20 mm.
- Four universal mounting brackets either for ceiling or for wall
- On/off switcher included
- Power cable located at **right** side of the screen housing seen from the front
- Flame - retardant projection surfaces - classification M1,M2 and B1
- Side black borders of 5 cm. and black dowel bar height 35 mm. - depth 20 mm. *(optional)*
- Screen housing available in different colours *(optional)*

The measures in the drawings are expressed in millimetres.

DIMENSIONS measures in cm

1:1 Ratio Viewing area (WxH)	4:3 Ratio Viewing area (WxH)	16:10 Ratio Viewing area (WxH)	16:9 Ratio Viewing area (WxH)	Overall dimensions A - C	Approx. net weight (Kg)
300 x 300	-	-	-	311 - 304	25
350 x 350	350 x 265	350 x 219	350 x 197	361 - 354	28
400 x 400	400 x 300	400 x 250	400 x 225	411 - 404	33
-	450 x 340	450 x 281	450 x 253	461 - 454	37

PROJECTION CLOTHS

Front projection surfaces	Gain	Rear projection surfaces <i>**no black borders**</i>	Gain
White	1.2	Rear Plus	1.1
Matte White	1.2	Front Rear	0.9
Microperforated	1.1		
Ultra HD*	1.2		
Bright Contrast 3D 0.8*	0.8		

Warranty: 5 years on the motor - 24 months on the other components

