

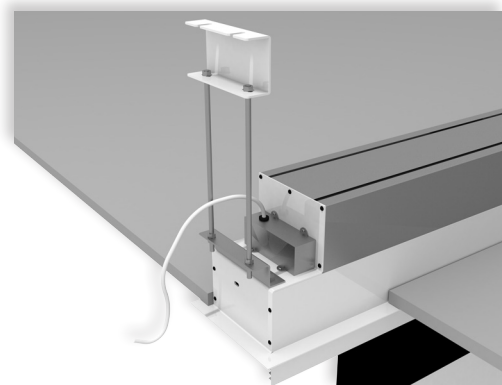

RAFFAELLO PROFESSIONAL is an in-ceiling electric projection screen, that has an innovative mechanical construction which makes it an ideal and unique solution for residential and AV professional environments. Its peculiarity is that, **once mounted inside the false ceiling, the product is completely hidden** and no visible openings can be seen. The mechanism is composed by two silent and fast motors, one for the opening of the trap door and the other for rolling down of the projection screen. **IMPORTANT:** The structure allows substitution of the projection surface rolling pipe without the need to uninstall the product completely.

Available in 4:3, 16:9 and 16:10 formats or bespoke sizes.



LEFT SIDE VIEW (motor side)

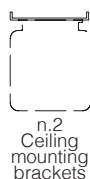

n.2
Ceiling
mounting
brackets



n.1
On/off
switcher

INCLUDED

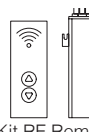

Kit RF Remote
control with
external
receiver

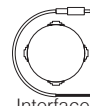

Interface
switch 12 volt

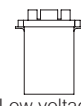

Low voltage
contact
interface

OPTIONAL pag 62-63



CEILING BRACKET

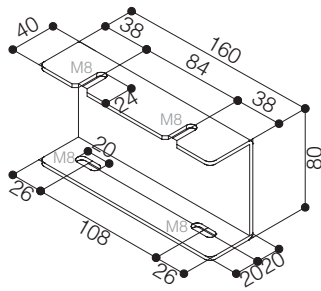

DIMENSIONS OF THE HOLE TO BE MADE IN THE FALSE CEILING

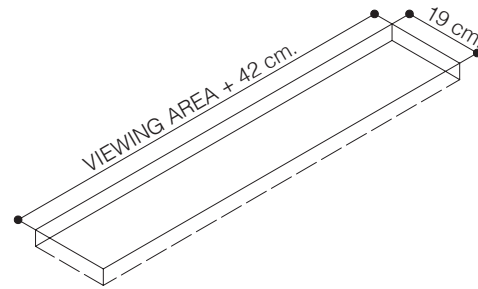

HOUSING SIDE VIEW

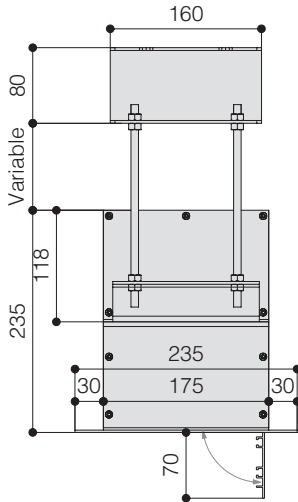

HOUSING FRONT VIEW

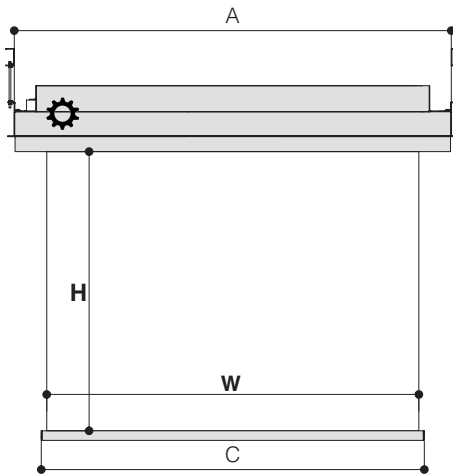
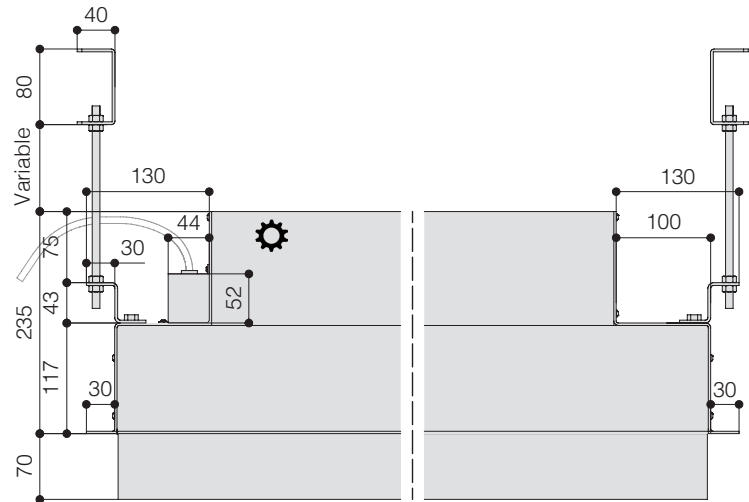

TECHNICAL SPECIFICATIONS

- Silent motor system provides a smooth and quiet operation
 - Power: **9 Nm**
 - Speed: **26 rpm**
 - Power supply: **230V / 50 Hz**
 - Consumption: **184 W**
 - Certification: **IMQ**
- Housing manufactured from aluminium
- Lower part of the housing, trap door and bezel sprayed with white epoxy powders (RAL 9010)
- White dowel bar: height 35 mm. - depth 20 mm.
- Two ceiling mounting brackets with four threaded rods 100 cm. long
- On/Off switcher included
- Screen standard supplied with **cloth dropping** down from the front side of the housing
- Flame - retardant projection surfaces - classification M1, M2 and B1
- Side black borders of 5 cm. and black dowel bar (optional)
- Minimum height needed into the false ceiling: 25 cm.
- Screen housing available in different colours (optional)

The measures in the drawings are expressed in millimetres.

DIMENSIONS measures in cm

1:1 Ratio Viewing area (WxH)	4:3 Ratio Viewing area (WxH)	16:9 Ratio Viewing area (WxH)	16:10 Ratio Viewing area (WxH)	Overall dimensions A - C	Approx. net weight (Kg)
160 x 160	160 x 120	160 x 100	160 x 90	201 - 164	39
180 x 180	180 x 135	180 x 112	180 x 101	221 - 184	41
200 x 200	200 x 150	200 x 125	200 x 112	241 - 204	44
220 x 220	220 x 165	220 x 137	220 x 124	261 - 224	47
250 x 250	250 x 190	250 x 156	250 x 140	291 - 254	52
300 x 300	300 x 225	300 x 187	300 x 169	341 - 304	59
350 x 350	350 x 265	350 x 219	350 x 197	391 - 354	66
400 x 400	400 x 300	400 x 250	400 x 225	441 - 404	73

PROJECTION CLOTHS

Front projection surfaces	Gain	Rear projection surfaces <i>**no black borders**</i>	Gain
White	1.2	Rear Plus	1.1
Matte White	1.2	Front Rear	0.9
Microperforated	1.1		
Fibre Matte*	1.25		
Ultra HD*	1.2		
Bright Contrast 3D 0.8*	0.8		

*Limited in height

Warranty: 5 years on the motor - 24 months on the other components

