



VARIOCLIP  
MANUAL



## CENTRE SUPPORT

---

Consists of plug in elements with interlocking and safety bolts. Adaptable to any frame size.

## FOLDABLE LEGS

---

Standard delivery AT32/64.  
According to the size of the projection screen five different leg types are available.

## WING SCREWS

---

Yellow bag for wing screws and leg connectors.

## PROJECTION SCREEN BAG

---

Lined storage bag for projection screen



## SOFTBAG WITH WHEELS

padded , tearproof nylonbag  
with wheels and carrying straps  
small 128x25x30 cm  
big 133x31x35 cm

## FRAME VARIOCLIP

Modular plug-in frame system  
Basic frame (4 corners 210x210 cm or  
210x160 cm) folded, standard and  
supplementary frame components  
Hardened aluminum alloy guarantees  
highest stability at lowest product weight.

## ASSEMBLY INSTRUCTION

# GENERAL

## QUALITY AND SAFETY:

This projection screen is in accordance with the safety regulations in DIN standard 19045 and DIN 56950-40. The screen fabric is compliant with DIN 4102 part 1 and the specifications of the corresponding data sheet. For the technical details and projection-specific material parameters please refer to the corresponding product data sheet. [www.AVstumpfl.com/projectionmaterials](http://www.AVstumpfl.com/projectionmaterials)

## WARRANTY:

The warranty period for production deficiencies is 5 years for the frame elements and 24 months for the projection surface. Mobile projection screens are developed for indoor use only. Any damage and consequential damage caused by outdoor use is not covered by warranty. The general terms and conditions are available at <http://avstumpfl.com/agb>

## FRAME ELEMENTS:

The frame elements, legs and additional elements are maintenance-free!

## PROJECTION SURFACE:

The projection surface is packed into a separate soft bag to avoid any damage by the frame parts, bleaching and discoloration. Additionally following handling instructions have to be adhered to:

- ! Do not bring printed and coloring objects (instructions, magazines, etc.) in contact with the projection surface
- ! Do not mark the projection surface!

Colors penetrate the projection surface and cannot be cleaned anymore!

Store the projection surface cleaned and dry at room temperature only!

The projection surface has to be folded with the front layer inside; in order to avoid soil and damage.

## COLD BREAK:

A projection foil must never be stored or transported below 0 ° C. There is a risk of a cold break! The film becomes very brittle and splinters like glass! When transporting the projection surface at low temperatures, do not unfold the surface unless it has reached its full elasticity at room temperature. Otherwise there is the risk of cold break of the projection screen. When folding the projection surface, insert the enclosed foamed plastic foil between snap buttons and surface to avoid permanent marks.

## CLEANING OF THE PROJECTION SURFACE:

Use a white clean cotton cloth saturated with clear water (optionally mild soap water) and wipe the area gently in one direction (no circular motion). Wipe dry with another cotton cloth.

To clean a stubborn stain, use methylated spirit and follow the same procedure.

Clean rear projection surfaces in case of imperative only!

Subject to modifications, errors expected !

# VARIOCLIP FRAME COMPONENTS

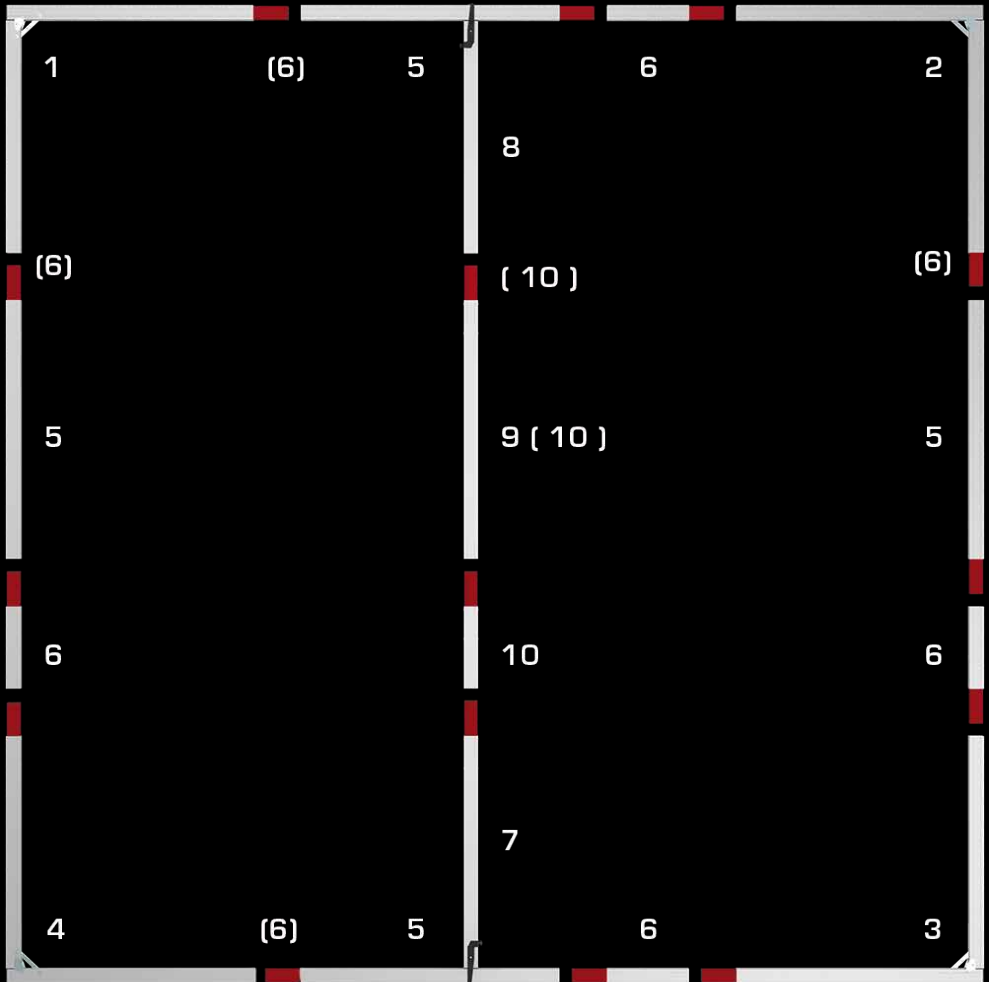

## FRAME SET UP

All components of the mobile projection screen are labeled.

For assembly, start with the basic frame. Unfold the corner elements 1 to 4. Do not engage the shear joints now and lay out the components according to their labeling. The standard elements 5 (110cm) and supplementary frame components 6 (below 110cm) have to be inserted according to their labeling (see sketch above). In case of two supplementary frame components 6 and (6) per frame side, the standard elements 5 (110cm) have to be placed in between of the two supplementary frame components 6 and (6). Engaging the shear joints ensures the maximum screen stability.

# CONNECTION TYPES

Depending on the application and screen size three different connection types are available for VARIOCLIP.

## VARIOCLIP

The quick and easy plug-in connection for small to medium sizes when installed with legs.

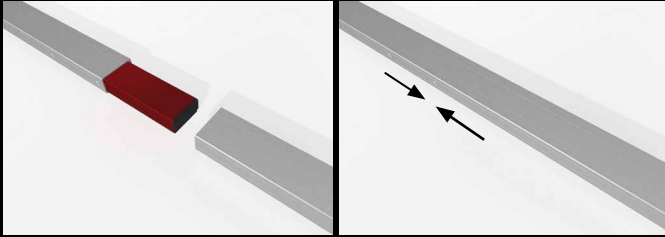

## VARIOCLIP LOCK

The plug-in connection with additional locking for larger screens and/or "flying- screen" mounting. A simple 90° rotation and the connection is secured. No tool is required.

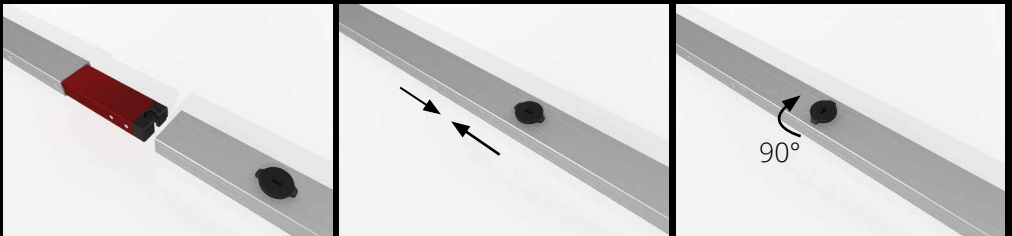

## VARIOCLIP CLAMP

The perfect profile connection for very large projection screens ensures optimum form stability and minimum deflection. The frame sections are joined together free of play by the clamp bar with the included Torx screwdriver.

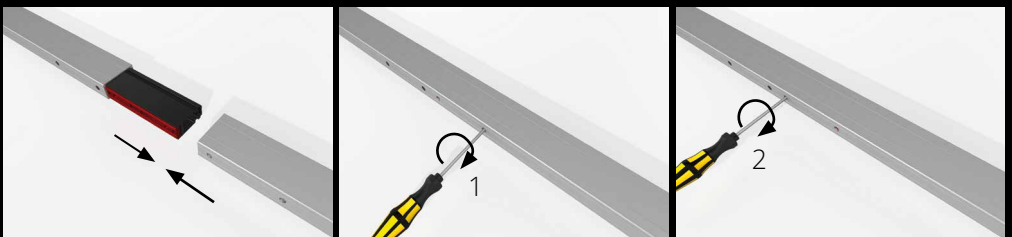

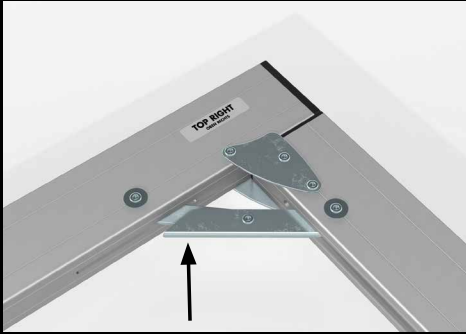

## FRAME SET UP

Engaging the shear joints ensures the maximum screen stability.

## CENTRE SUPPORT AND HORIZONTAL STRUT

The center support consists of a profile „centre support bottom“ 7 and a profile „centre support top“ 8 and according to the screen size, and additionally of parts “standard component - centre support“ 9 (110cm) and a “supplementary component-centre support“ 10. These components are assembled so that the profile “centre support“ 7 and 8 are placed with the clamp facing outside. Slide the centre support between top and bottom edge of the assembled screen frame, align it centrally and secure the centre support with the wing screws. VARIOCLIP and VARIOCLIP LOCK are supplied with one middle strut and middle leg from a width of 700cm. At very high projection screens in addition to the center supports a horizontal strut is fitted. Please follow the enclosed set up scheme.

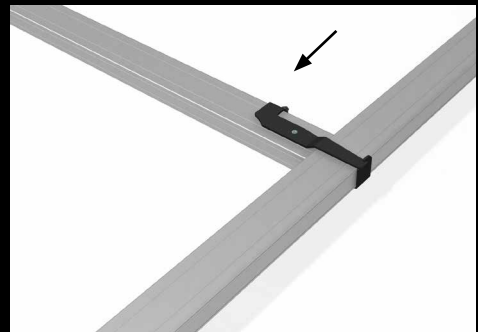
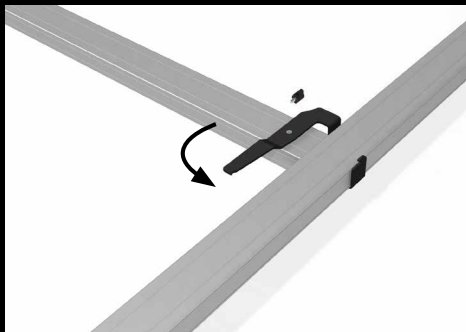
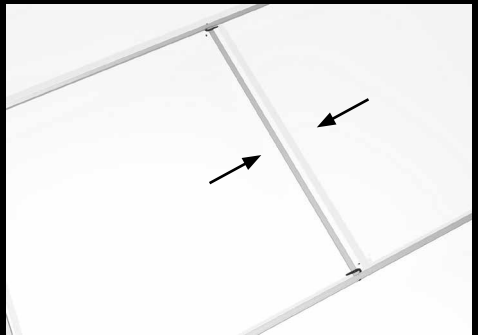
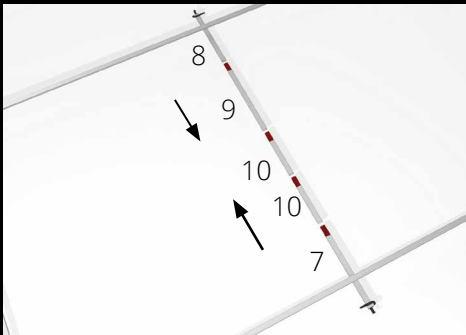

# FOLDABLE LEGS FOR VERTICAL ADJUSTMENT

The legs are foldable for compact transport volume. All profile elements are connected with snap joints or hinges inseparable.

## MOUNTING

**1** First open the vertical elements of the legs (with holes) **2-3** The snap joints engage automatically. **4** To secure the legs by a single person, we recommend the use of set up supports. Slide on with the upper round steel fork two set up supports each on the legs and center supports. Lay on the legs on the bottom bow and align the hole pattern matching the connection points at the desired set-up height. (Please follow the separate instructions for set up support). **5** The feet are secured with two wing screws on the lower vertical frame element and the clamp connectors are attached at the top of the feet **6**.

Note: Please find the instructions for telescopic support attachment under chapter SET UP

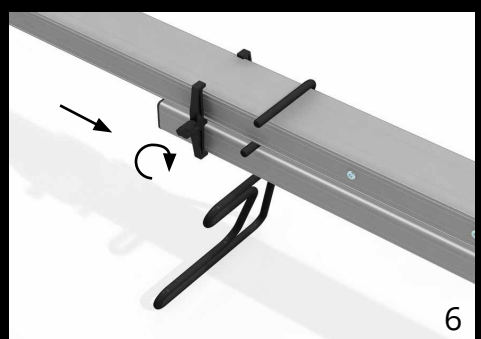
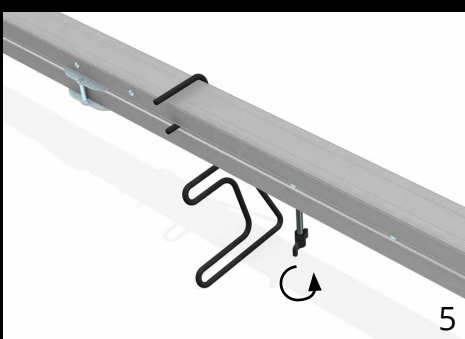
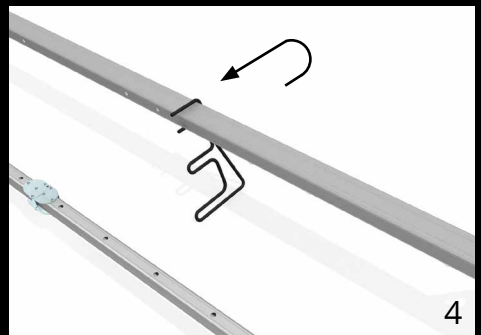
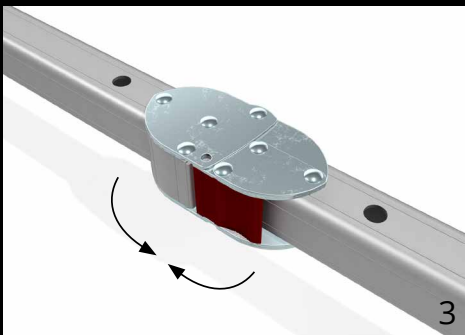
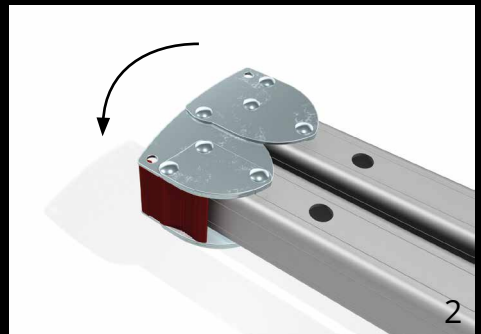
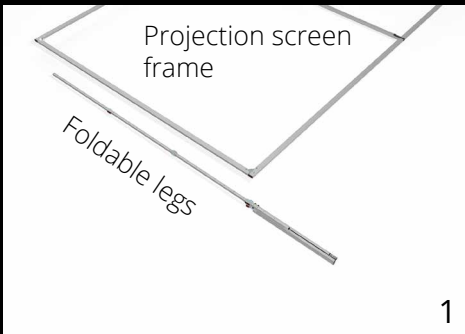



# LEG TYPES

Please mind the maximum set-up height of the legs:

**min:** minimum height of the bottom edge of the frame

**max:** maximum height of the bottom edge of the frame without additional safeguarding

Set-up heights are points of reference and have to be adapted in accordance with the screen size and ambient conditions. Set-up heights are based on absolute vertical alignment at indoors without additional force effects (e.g.: wind, air condition draught,..)

## Height adjustment in steps of 6" (152,4mm)

compatible with all mobile AV Stumpfl screen systems

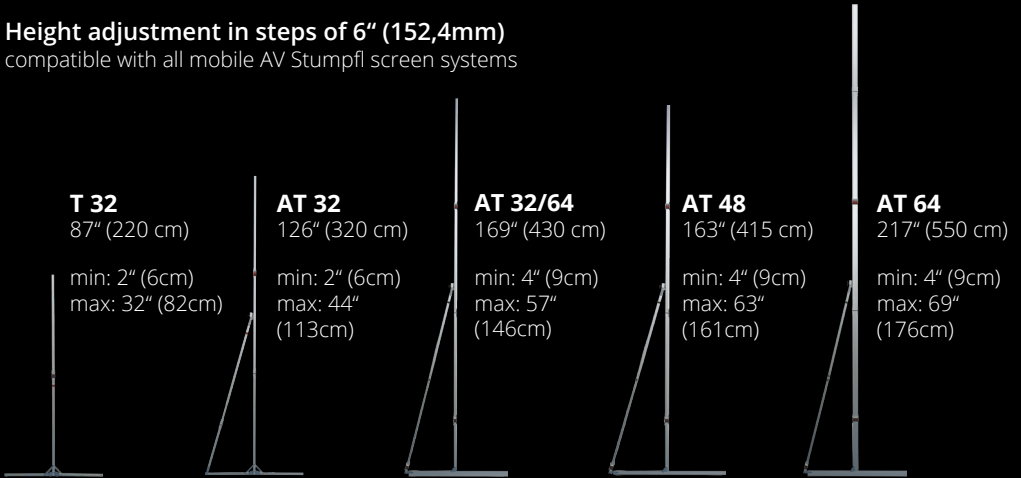

When a high degree of stability is needed, especially with large screens or a high set-up height, we recommend using following legs: AT32 for MONOBLOX 32 and AT48 or AT64 for MONOBLOX 64. AT-Legs have a telescopic support that is tightened with two wing screws.

## Height adjustment in steps of 1" (25,4mm)

According to the screen frame height and the desired set-up height the legs can be put together in different lengths.

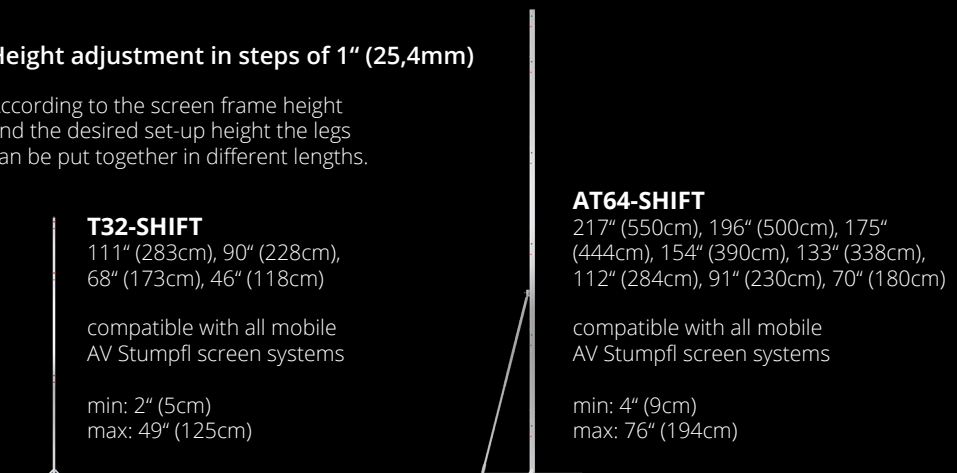

## PROJECTION SURFACE

In projection system VARIOCLIP the projection surface is equipped with the patented QUICKCLIP™ instead of snap fasteners. (see picture right).



## SURFACE MOUNTING

**1** Lay out the surface on the frame with the label „OBEN-TOP“ corresponding with the upper frame bar.  
**2-3** Hook the first QUICKCLIP™ into the slot of the corner plug and additionally a second QUICKCLIP™ along the vertical and horizontal profile groove. Repeat this step according to the order in picture **1**.  
**4** Finally stretch all the remaining QUICKCLIP™ over the profile edge. The QUICKCLIP™ snap into place automatically.

! Please mind the instructions for projection surfaces in chapter GENERAL!

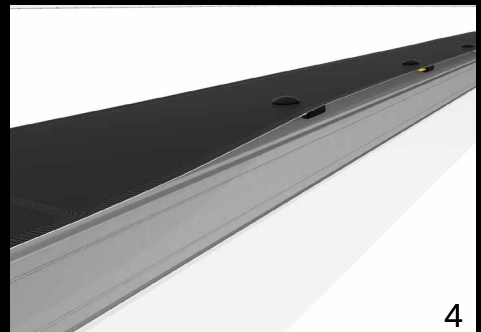
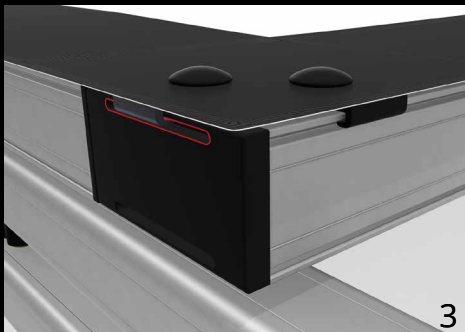
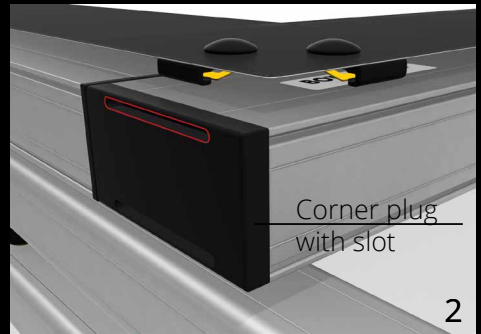
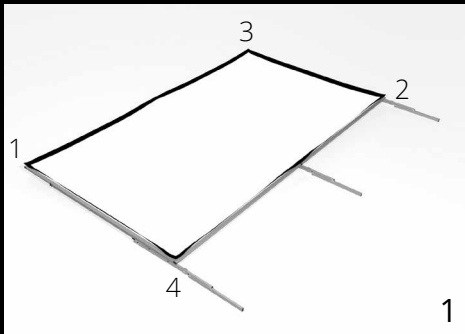

# SET UP

**1** Lift the projection screen with one person at each of the top corners and put it up by supporting the screen along the vertical frame elements. To avoid mechanical overload and damage of the screen elements and legs with large screens or high set-up height, the screen has to be raised with an appropriate number of persons or rather by using hoisting devices.

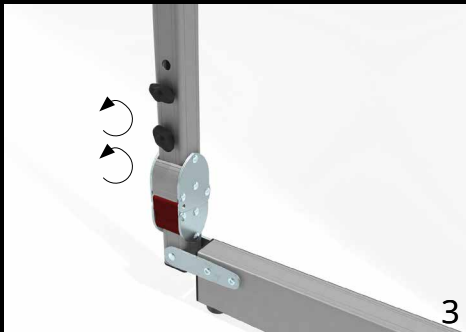
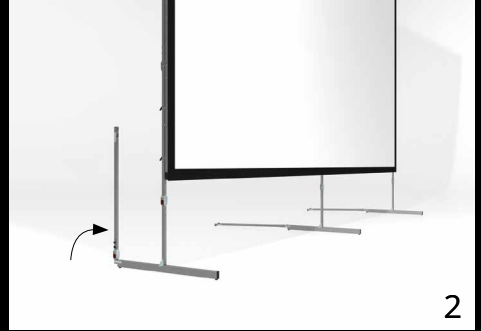
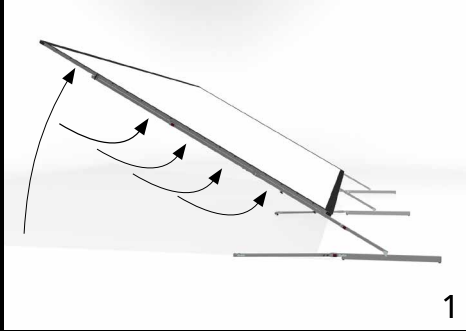

## TELESCOPIC SUPPORT ATTACHMENT

**2** Raise the telescopic support. **3** Untighten the wing screws. **4** Bolt the telescopic support with the wing screw M8x50mm (yellow).

**5** Finally retighten the telescopic support clamp.

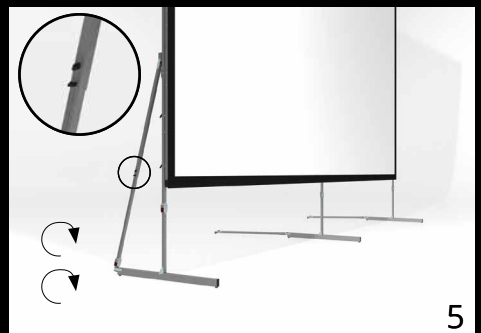

# BREAK DOWN

Open the shear joints and telescopic leg supports with one person next to each of the foldable legs. Bring down the screen by supporting the screen along the legs and vertical frame elements towards the top corner edges.

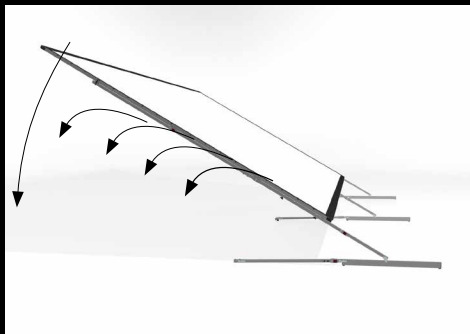

# BREAK DOWN NOTE

**1** To detach the projection surface you have to remove the QUICKCLIP™ on one vertical and one horizontal frame side only. **2** Now the surface can be pulled off the frame easily.

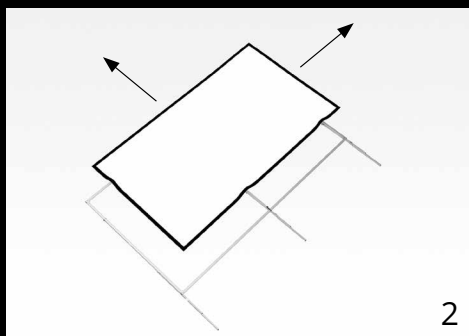
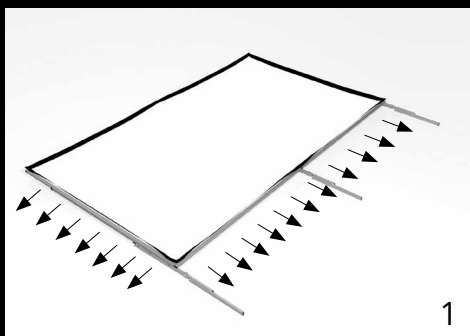

# ACCESSORIES

## ANTI-SWAY BRACE

To increase the side-stability of the projection screen the in length variable Anti-Sway Brace has to be screwed on the leg and clamped to the basic frame.

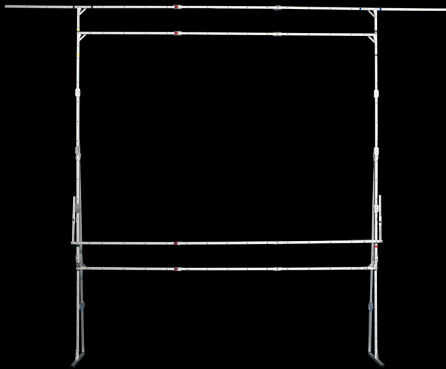
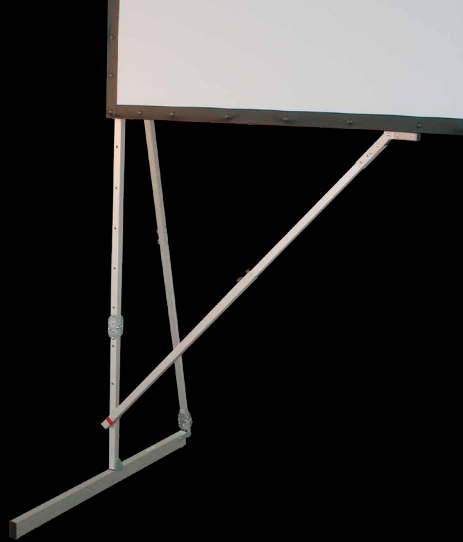

## DRAPEKIT

To drape a projection screen with decoration curtains. Depending on requirements, various frame parts can be used to attach the drapes Valance Bar (top drape), Wing Bar (left and right drape) and Skirt Bar (bottom drape - height adjustable for aspect ratio change) Heavy drapes have to be attached after the set up to avoid damaging of frame parts!



## EASYFLY™

### SUSPENSION CLAMP WITH EYEBOLT

This adapters for Varioclip can be attached quickly and easily at any point. The eyebolt fixes the adapter to the profile, offering professional hanging possibilities. Available for profile sizes 32x32mm and 64x32mm. max. load 30 kg/60 lbs.



## SET UP SUPPORT

The optional available, set up support allows an easy mounting of the legs. By means of the 4 round bar holders the wings screws can be bolted by one person only without holding the frame and leg in position.

## FLIGHT CASE

As an option we offer sturdy, stackable transport cases with rollers for all mobile projection screens.

Transport case small: size 123 x 38 cm, height 34 cm  
Transport case large: size 134 x 38 cm, height 37 cm

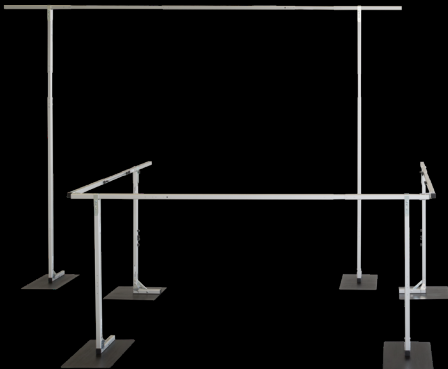

## DRAPE RUNOFF

This universal and transportable Drapery System can be used as independent partition, to mark out control areas or to allow flexible room design. A few elements combined with the telescopic system suffice to accomplish a variety of decorative purposes – no tools required. The decoration material is attached by Velcro fasteners.